

2/2-way compact flange ball valve

- Manually operated
- Full opening

Compact flange ball valve in steel or stainless steel to regulate medium flow.

Technical data	
Orifice	Manually operated steel DIN/ISO 5211 DN 15-150 Manually operated stainless steel DIN/ISO 5211 DN 15 - 150
Body material	Steel 1.0619 Stainless steel 1.4408
Ball material	Stainless steel 1.4401
Seal material	PTFE
Pressure range	Technical vacuum (10^{-3} Torr) ... 40 bar ¹⁾ PN 40: Orifice 15 ... 50 mm PN 16: Orifice 65 ... 150 mm (other pressure ranges on request)
Temperature range	
Version steel DIN/ISO 5211	-10°C ... +160°C
Version stainless steel DIN/ISO 5211	-10°C ... +160°C (see also pressure temperature restart points)

¹⁾ Pressure values [bar]: Measured as overpressure to the atmospheric pressure

Steel version, DIN / ISO 521 flange fitting

Torque

Orifice [mm]	Torque
15	8
20	11
25	15
32	22
40	26
50	42
65	56
80	84
100	105
125	139
150	184

Pressure temperature restart points

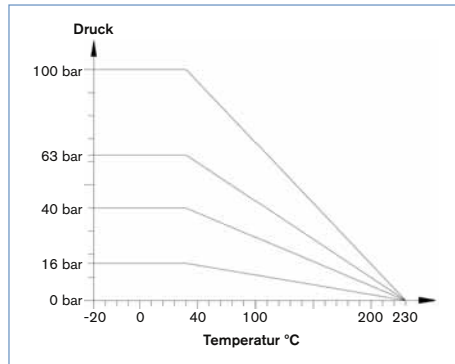

Kvs value

Orifice [mm]	Kvs value water [m³/h]
15	35
20	46
25	72
32	105
40	170
50	275
65	507
80	905
100	1414
125	2362
150	3674

¹⁾Pressure values [bar]: Measured as overpressure to the atmospheric pressure

Kvs value [m³/h]

Nominal flow-rate value for water acc. to VDI/VDE 2173.

Measured at a medium temperature from +15°C, 1 bar¹⁾ pressure at inlet and free outlet

Stainless steel version, DIN / ISO 5211 flange fitting

Torque

Orifice [mm]	Torque
15	8
20	11
25	15
32	22
40	26
50	42
65	56
80	84
100	105
125	139
150	184

Pressure temperature restart points

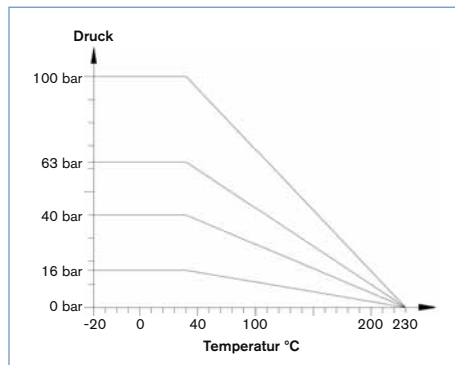

Kvs value

Orifice [mm]	Kvs value water [m³/h]
15	35
20	46
25	72
32	105
40	170
50	275
65	507
80	905
100	1414
125	2362
150	3674

¹⁾Pressure values [bar]: Measured as overpressure to the atmospheric pressure

Kvs value [m³/h]

Nominal flow-rate value for water acc. to VDI/VDE 2173.

Measured at a Medium temperature from +15°C, 1 bar¹⁾ pressure at inlet and free outlet

Material

Steel version, DIN / ISO 5211 flange fitting

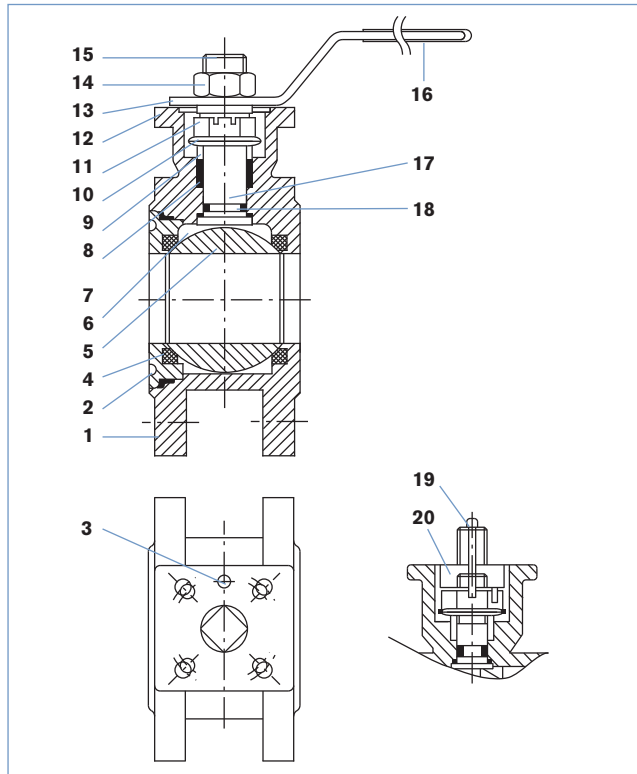

1	Body	1	1.0619
2	Screw-in fitting	1	1.0619
3	Stopper	1	1.4301
4	Ball seal	2	PTFE
5	Ball	1	1.4301
6	Pressure ring	1	PTFE
7	Body seal	1	PTFE
8	Ball stem seal	1 unit	PTFE
9	Packing gland ring	2	1.4301
10	Spring cup	2	SUS 301
11	Packing gland	1	1.4301
12	Safety ring	1	1.4301
13	Handle	1	1.4301
14	Locknut	1	1.4301
15	Gearshift lever shaft	1	1.4301
16	Handle cover	1	Plastic
17	Anti-static (optional)	1	1.4301
18	O-Ring	1	FKM
19	Spigot	1	1.4301
20	Driver	1	1.4301

Integrated DIN/ISO 5211-Flange configuration

Stainless steel version, DIN / ISO 5211 flange fitting

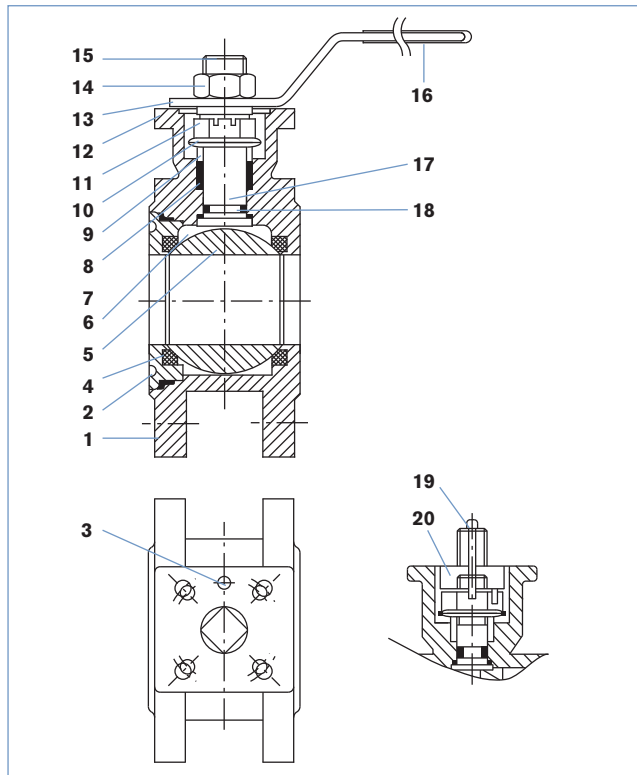

1	Body	1	1.4408
2	Screw-in fitting	1	1.4408
3	Stopper	1	1.4301
4	Ball seal	2	PTFE
5	Ball	1	1.4401
6	Pressure ring	1	PTFE
7	Body seal	1	PTFE
8	Ball stem seal	1 unit	PTFE
9	Packing gland ring	2	1.4301
10	Spring cup	2	SUS 301
11	Packing gland	1	1.4301
12	Safety ring	1	1.4301
13	Handle	1	1.4301
14	Locknut	1	1.4301
15	Gearshift lever shaft	1	1.4401
16	Handle cover	1	Plastic
17	Anti-static (optional)	1	1.4301
18	O-Ring	1	FKM
19	Spigot	1	1.4301
20	Driver	1	1.4301

Integrated DIN/ISO 5211-Flange configuration

Steel version, DIN / ISO 5211 flange fitting

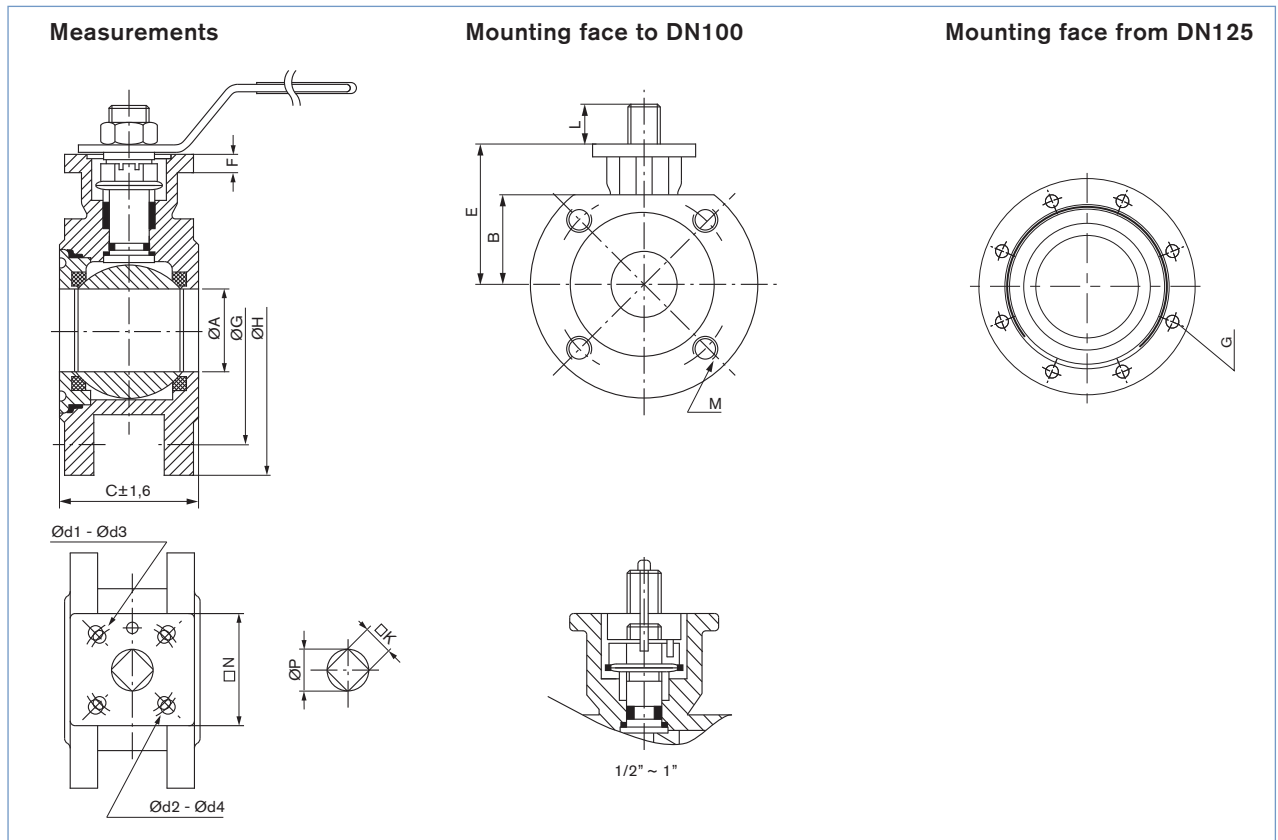

Dimensions [mm]

Orifice [mm]	C [mm]	Ø G [mm]	Ø H [mm]	Ø A [mm]	B [mm]	E [mm]
15	40	65	95	15	34.5	60.0
20	44	75	105	20	38.5	64.3
25	53	85	115	25	44.6	64.6
32	58.4	100	135	32	51	69.0
40	62	110	145	38	55	76.3
50	78	125	155	50	63	85.7
65	100	145	185	65	73.5	105
80	120	160	200	76	94	123
100	152	180	220	96	105	132
125	180	188	250	114	125	157.5
150	215	212	285	135	142.5	172.5

Orifice [mm]	ISO 5211	Ø d1 [mm]	Ø d2 [mm]	Ø d3 [mm]	Ø d4 [mm]	K [mm]	L [mm]	M [mm]
15	F03/F04	36	42	6.0	5.5	9	8	M12x1.75
20	F03/F04	36	42	6.0	5.5	9	11	M12x1.75
25	F04/F05	42	50	5.5	7.0	11	11	M12x1.75
32	F04/F05	42	50	5.5	7.0	11	11	M16x2
40	F05/F07	50	70	7.0	8.5	14	17	M16x2
50	F05/F07	50	70	7.0	8.5	14	15	M16x2
65	F07	-	70	-	9.0	17	17	M16x2
80	F07	-	70	-	9.0	17	17	M16x2
100	F07/F10	70	102	9.0	10.5	17	29	M16x2
125	F10/F12	102	125	10.5	12.5	27	36	M16x2 (8 hole)
150	F10/F12	102	125	10.5	12.5	27	36	M20x2.5 (8 hole)

Ordering chart

Orifice [mm]	Item no.
15	788 860
20	788 861
25	788 862
32	788 863
40	788 864
50	788 865
65	788 866
80	788 867
100	788 868
125	788 869
150	788 870

Stainless steel version, DIN / ISO 5211 flange fitting

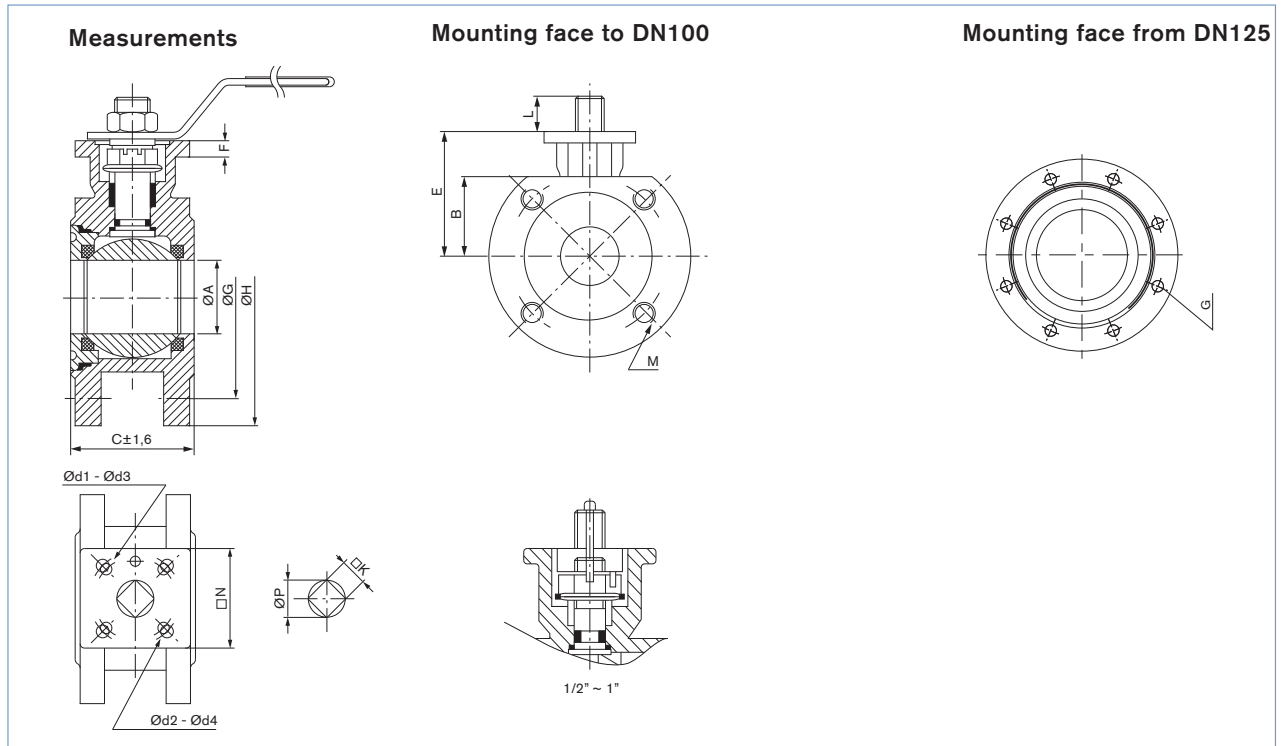

Dimensions [mm]

Orifice [mm]	C [mm]	Ø G [mm]	Ø H [mm]	Ø A [mm]	B [mm]	E [mm]
15	40	65	95	15	34.5	60.0
20	44	75	105	20	38.5	64.3
25	53	85	115	25	44.6	64.6
32	58.4	100	135	32	51	69.0
40	62	110	145	38	55	76.3
50	78	125	155	50	63	85.7
65	100	145	185	65	73.5	105
80	120	160	200	76	94	123
100	152	180	220	96	105	132
125	180	188	250	114	125	157.5
150	215	212	285	135	142.5	172.5

Orifice [mm]	ISO 5211	Ø d1 [mm]	Ø d2 [mm]	Ø d3 [mm]	Ø d4 [mm]	K [mm]	L [mm]	M [mm]
15	F03/F04	36	42	6.0	5.5	9	8	M12x1.75
20	F03/F04	36	42	6.0	5.5	9	11	M12x1.75
25	F04/F05	42	50	5.5	7.0	11	11	M12x1.75
32	F04/F05	42	50	5.5	7.0	11	11	M16x2
40	F05/F07	50	70	7.0	8.5	14	17	M16x2
50	F05/F07	50	70	7.0	8.5	14	15	M16x2
65	F07	-	70	-	9.0	17	17	M16x2
80	F07	-	70	-	9.0	17	17	M16x2
100	F07/F10	70	102	9.0	10.5	17	29	M16x2
125	F10/F12	102	125	10.5	12.5	27	36	M16x2 (8 hole)
150	F10/F12	102	125	10.5	12.5	27	36	M20x2.5 (8 hole)

Ordering chart

Orifice [mm]	Item no.
15	784 971
20	787 066
25	784 775
32	784 776
40	784 777
50	784 778
65	784 779
80	784 780
100	784 781
125	784 968
150	784 969

To find your nearest Bürkert facility, click on the orange box → www.burkert.com

In case of special application conditions, please consult for advice

Subject to alteration.
© Christian Bürkert GmbH & Co. KG

0810/1_EU-en_00895108